



DE CEUSTER
BOUWKRANEN - GRUES

Sky760
69 meter



Sky760 - 69 m

#torenkranen
#SkyCranes

De Sky760 is het vlaggenschip van De Ceuster. Deze torenkraan wordt ingezet bij uw megaprojecten waar aanzienlijke lengtes en ruime gewichten vereist zijn. Met deze torenkraan behandelt u al uw lasten alsof het kinderspel is. Bovendien beschikt dit type nog altijd over een slanke mast met bijhorend plaatsbesparend chassis. Kortom, deze torenkraan bevat al het beste van zijn kleinere broertjes, maar dan net met dat tikkeltje meer.

EXCLUSIVE
PARTNER
BENELUX
since 1988

sky
CRANES®

www.deceuster.be



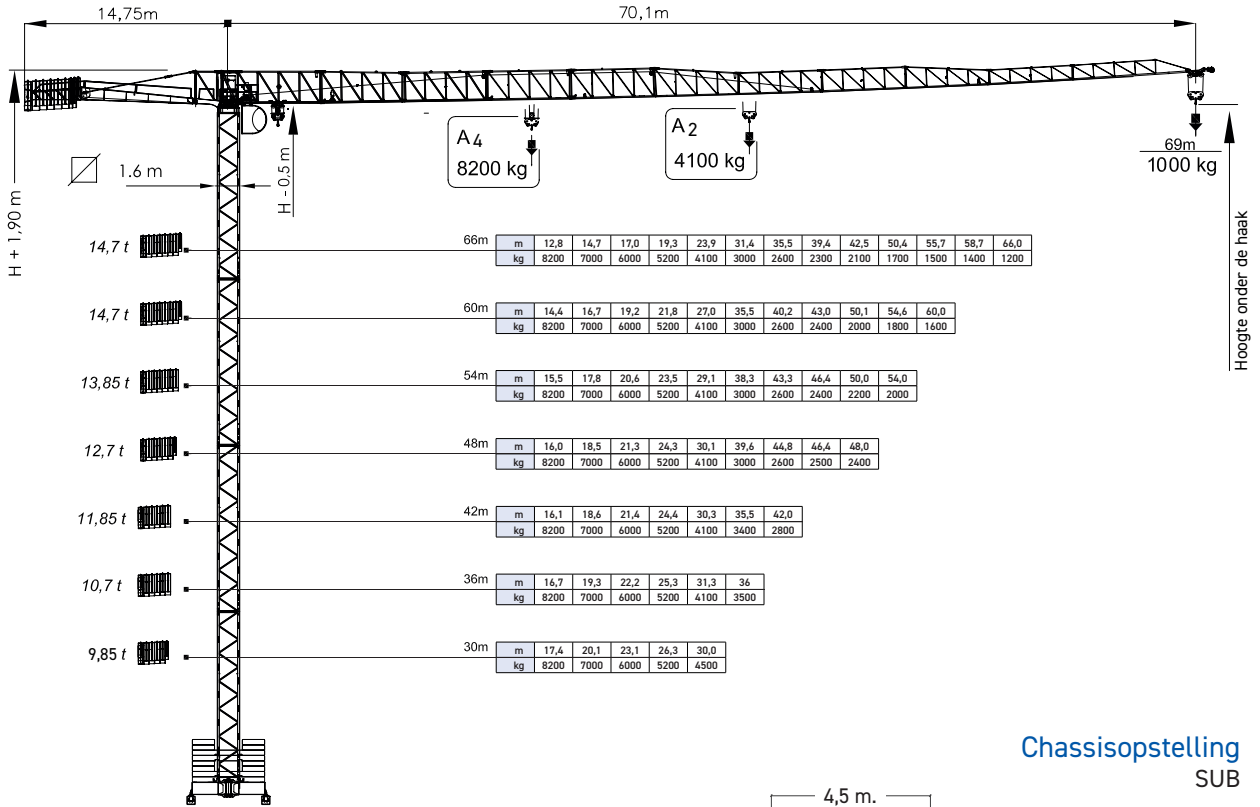

Omschrijving	Detail
Motorisatie	Us460i
Voltage	400 v
Vermogen	40 kW

Karakteristieken

Prestaties	Enkele inschering		Dubbele inschering	
	Snelheid	Max. gewicht	Snelheid	Max. gewicht
Hijzen (1ste)	5 m/min	4 100 kg	2,5 m/min	8 200 kg
Hijzen (2de)	33 m/min	4 100 kg	16,5 m/min	8 200 kg
Hijzen (3de)	50 m/min	2 600 kg	25 m/min	5 200 kg
Hijzen (4de)	50-76 m/min	2 600 kg	25-38 m/min	5 200 kg
Loopcat (1ste)	14 m/min	4 100 kg	14 m/min	8 200 kg
Loopcat (2de)	39 m/min	4 100 kg	39 m/min	8 200 kg
Loopcat (3de)	78 m/min	2 600 kg	78 m/min	5 200 kg
Draaien (progr.)	0,3 - 0,8 t/min	Maximaal gewicht		

Chassisopstelling SUB

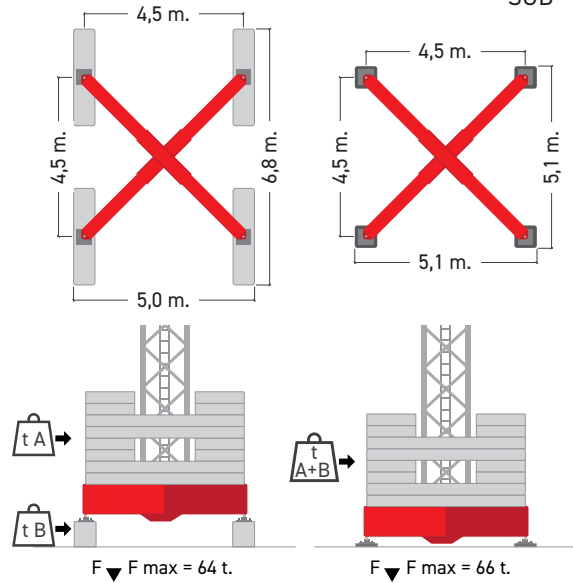

Sokkelopstelling SGT

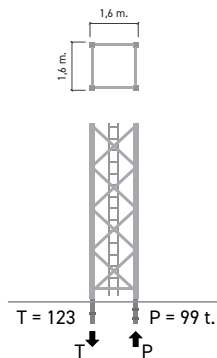

L x l x P : 5,50 x 5,50 x 1,60 m = 116 t

SUB

tA	H
t 72	m 50,9
t 66	m 44,9
t 54	m 38,9
t 48	m 32,9
t 42	m 26,9
	+
tB	t 6

Samenstelling mast

H - SGT	13,3	19,3	25,3	31,3	37,3	43,3	49,3
H - SUB	14,4	20,7	26,4	32,4	38,4	44,4	50,4
H - SUB + tB	14,9	20,9	26,9	32,9	38,9	44,9	50,9
	TTN	TTF + TTN	TTN	TTF + TTN + TTN	TTN + TTN + TTN	TTN + TTN + TTN + TTF	TTN + TTN + TTN + TTN



Stroomvoorziening (380V) en volledige lastentabel

Onder het chassis of de mast wordt een elektrische verdeelkast geplaatst waar ook extern nog 220 v en 380 v op afgenomen kan worden. Verder bevindt zich hier ook alle sturingsschakelaars voor zowel het licht als de windvrij van de reminrichting.



Giek in rood-witte signaalkleuren

Als de bouwkraan op grote hoogte geplaatst wordt dan dient de giek in de specifieke signaalkleuren te zijn. Al onze huurkranen zijn standaard voorzien van deze signalering.



Volledig frequentiegestuurd (softstart)

Deze bouwkransen zijn volledig frequentiegestuurd waardoor de piekstromen helemaal weg zijn en je zo energiezuiniger kunt werken.

 30 ~ 69 m

 1,60 x 1,60 m

 51,90 m

 4,50 x 4,50 m

 62,00 m

 5,00 x 6,80 m

 4,8 ~ 1,0 t

 380 V (63 A)

 II → 5,2 t
IV → 10,2 t

 radiografisch

 LED

 ECO

Centrale smering

Om slijtagegevoelige onderdelen te voorzien van de nodige smering tijdens het gebruik is iedere bouwkraan voorzien van een centrale smering, alweer een zorg minder!



Enkele referenties...

van klanten die werken met een torenkraan in deze categorie :





DE CEUSTER
BOUWKRANEN - GRUES



De Ceuster NXT
Van Doornelaan 2
B-2440 Geel

De Ceuster Wallonia
Rue de la Navère 10/5
B-5380 Fernelmont



1985



+150



+25



+10



+15



24/7

Together we build a strong future

info@deceuster.be | www.deceuster.be | T +32 11 54 24 13 | Service 0800 90 980

Find us on social media : @DeCeusterNV

